

Instruction Manual

Lonnie Bird's Divided Light Door Set

model number **800.525.11**

Congratulations on your new purchase! This manual will assist you during the use of your new set. This manual is not intended to teach you about wood-working. This is basic information for use of our product. It is assumed that you are an experienced woodworker and you are familiar with the basic woodworking skills and techniques necessary to use this product safely. If you are unsure after reading all material presented in the manual, please consult widely available books on woodworking techniques.

General Conditions

CMT USA, INC. reserves the right to make product changes without notice and without obligation to make these changes on products previously sold. Title and risk of loss or damage to the goods passes to the buyer upon consignment to the carrier regardless of who pays the shipping cost.

CMT is not liable for damages to goods, property, or persons, due to improper installation or misapplication of equipment.

Contents of Set

One each of the following items:

- | | |
|------------|-----------------------------|
| 835.851.11 | 1/2" Shank Rabbeting Bit |
| 855.802.11 | Rail and Stile Matched Pair |



CMT®

the only ORANGE one™

tel. 1-888-CMT-BITS • fax 1-800-268-9778

info@cmtusa.com • www.cmtusa.com

307-F Pomona Drive • Greensboro, NC 27407 • USA

Read and understand the entire contents of this manual before attempting assembly or operation of these tools! Inspect contents for shipping damage and shortages. Report problems to your distributor immediately.

IMPORTANT! Safety Precautions

SAFETY WARNINGS

- **Failure to heed all safety instructions and warnings regarding use of this product can result in serious bodily injury or death.**
- Carefully read all important safety instructions in the owner's manual that came with your machine before operating.
- If you do not have a manual, contact the manufacturer and obtain one before using any CMT bits or blades.
- Always wear eye protection in compliance with the current ANSI standard Z87.1 when operating any power tool.
- Always use proper guards and other safety devices when operating any machine.
- Carefully check router bits or blades prior to each use. Do not use if damage or defect is suspected.
- Do not exceed recommended RPM for any saw blade or router bit.
- Avoid wearing loose clothing or jewelry that may catch in a rotating saw blade or router bit.
- Unplug the machine when mounting or adjusting any saw blade or router bit.
- For best results always have router bits and saw blades professionally sharpened.

Specific Router Bit Safety Precautions

- Never force the bit or overload the router.
- Be sure that at least 3/4 of the shank length is inserted into the router collet.
- Never "bottom-out" the bit in the collet, the end of the shank should be about 1/8" from the bottom of the collet.
- Always make sure that the guide fences on your router table are firmly clamped in position before each use.
- Route in two or more passes when large amounts of stock must be removed.
- Use reduced speeds for large diameter bits.

Suggested Router Speeds

Bit Diameter	Maximum Speed
1" (25mm)	24,000 RPM
1-1/4" - 2" (30-50mm)	18,000 RPM
2-1/4" - 2-1/2" (55-65 mm)	16,000 RPM
3" - 3-1/2" (75-90 mm)	12,000 RPM

WARNING: The router bits included in this set are only to be used in a table mounted router. Do not attempt to use these bits in any hand held operation.



Using the Lonnie Bird Divided Light Door Set

This three-piece set allows you to make true divided light doors for fine furniture and cabinets. The set consists of a sticking bit to cut the decorative ovolo profile on the frame edges, a cope bit which shapes the mating profile on the ends of the stock, and a rabbeting bit for cutting the recess for the glass. Because the bits have guide bearings you can also create arched or curved frames.

The unique design of the cope bit allows you to use full-length tenons to create strong, authentic mortise-and-tenon joinery. As the stock is coped, the tenon passes over the bit. The set is designed for 7/8" wide bars as you might find on the doors of a corner cupboard for example.

Making a Divided Light Door

By Lonnie Bird

First Make a Drawing

Begin with the drawing, which shows the design and dimensions of the door.

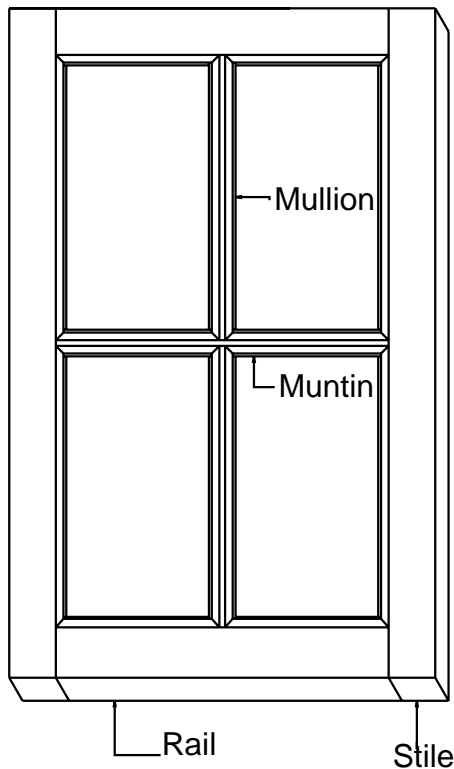

Mill the Stock

Next, select stock and mill it to the sizes needed for the door you intend to build. Clear, straight-grain stock is best because it will not have a tendency to warp. Also, when sizing the stock for the bars, I rip each piece wide enough to make two bars. After cutting the tenons and the cope, I rip the bars to final width. This method ensures greater accuracy. Its also helpful to mill a few extra pieces for use when setting up each cut.

Layout the Joints Next

I begin the layout process with a stile (see Fig. 1). First, I mark the location of the mortises for the top and bottom rails; then I layout the mortises for each muntin. For greatest accuracy I clamp the stiles and mullions edge-to-edge and transfer the layout marks.

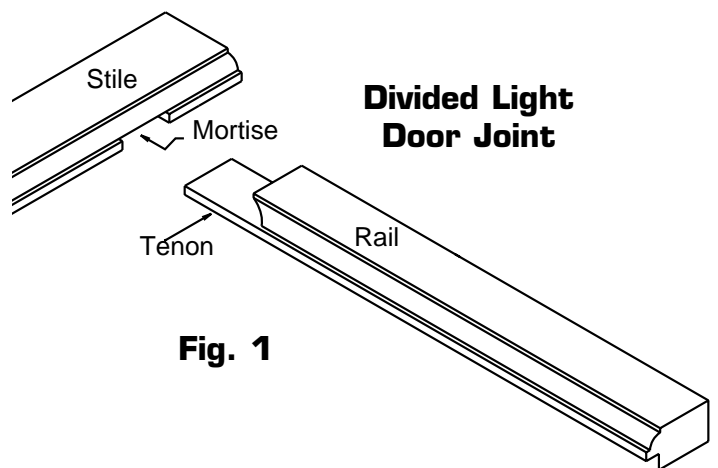

Fig. 1

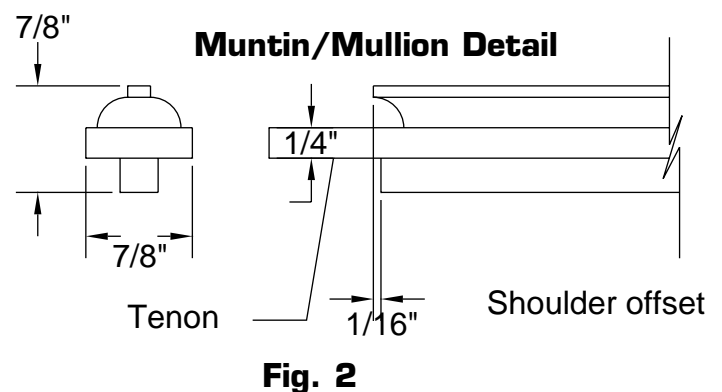

Fig. 2

The next step is to layout the tenons on the muntins, mullions and rails. Remember that the tenon shoulders are offset (see Fig. 2)

Cut the Mortises

Cut the mortises first, using a router or a hollow chisel mortiser. You'll need to cut mortises in all the stock except for the mullions, which have no mortises. Also, remember to cut the mortises on the muntins all the way through.

Cut the tenons

The next step is to cut the tenons for a friction fit with the mortise. Although I prefer to use a tablesaw for this step, you can use your favorite method. However remember to offset the shoulders by 1/16" (see fig. 2)

Shape the Cope

Once the joinery is complete, the next step is to shape the cope. The cope profile is positioned just above each tenon. During assembly the cope matches the sticking profile for a perfect fit.

Shaping The Cope

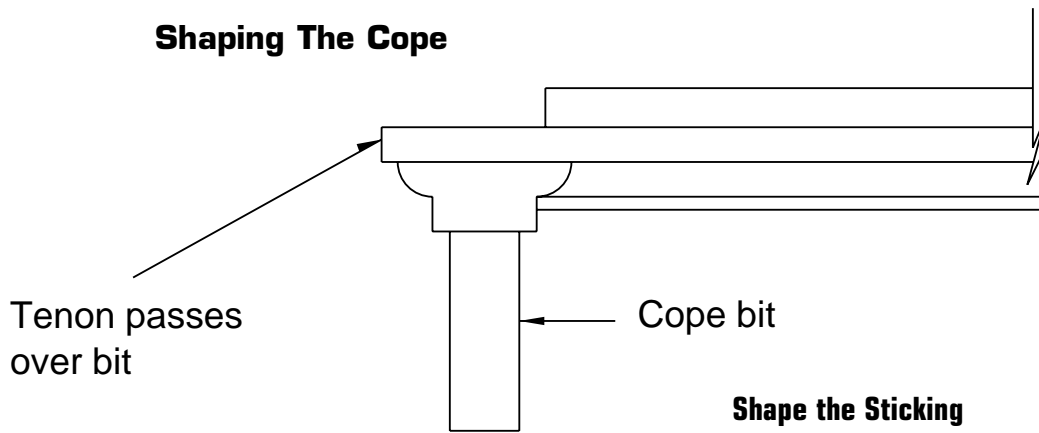

To prepare for this cut, first mount the cope router bit in your router table and adjust the height. The bit is at the correct height when it makes slight contact with the tenon. To make this adjustment, place the workpiece on the router table face down, then, with the power off, gradually raise the bit until it skims the surface of the tenon.

Once the height is set, the next step is to position the fence. I use a strip of 1/4" thick plywood as a fence; it registers against the tenon shoulder to control the cutting depth. A small cutout in the center of the fence provides an opening for the bit. I use a miter gauge to guide the workpiece through the cut.

Secure the fence to the router table with a pair of small clamps and make a trial cut. Test the fit of the cope to the sticking and make any necessary adjustments to the fence. Finally, cut the cope on each piece of stock that has a tenon (rails, muntins and mullions).

Shape the Sticking

The next step is to shape the sticking. But first rip the bars to the final size (7/8"). To safely shape the narrow bars, I use a simple jig: a board with an L shaped notch in which the bar fits. 1/4" thick plywood provides a cap for the jig, which applies pressure on the workpiece during the cut.

Cut the Rabbets

The final step before assembly is to cut the rabbets for the glass. To hold the bar securely while shaping I use the same jig that I used when shaping the sticking. First cut the rabbet along the first edge on all the stock; then tack a strip of wood into the jig to fill the rabbet and provide stability during the second cut.

After shaping all the frame and bar pieces, dry clamp the final assembly to check for fit. Then proceed to final glue-up and assembly.

Jig For Shaping The Sticking

